

The insert for the bezel was black, with the letters PMD in red.

A second steering wheel option was available in 1970, the Formula wheel (RPO 464, UPC NK3). This wheel was identical in all respects to the wheel used on the 1969 Firebird Trans Am. The padded rim (part number 546296) used a horn button cover (part number 480479) with the Pontiac crest in the center of the insert. This wheel was only available in black and only with power steering.

Directional signal canceling cams were different and not interchangeable between the 1968 and the 1969-70 columns.

Year	Application	Part Number
1968	With tilt column	399294
	Without tilt column	399292
1969-70	With tilt column	7805224
	Without tilt column	7804768

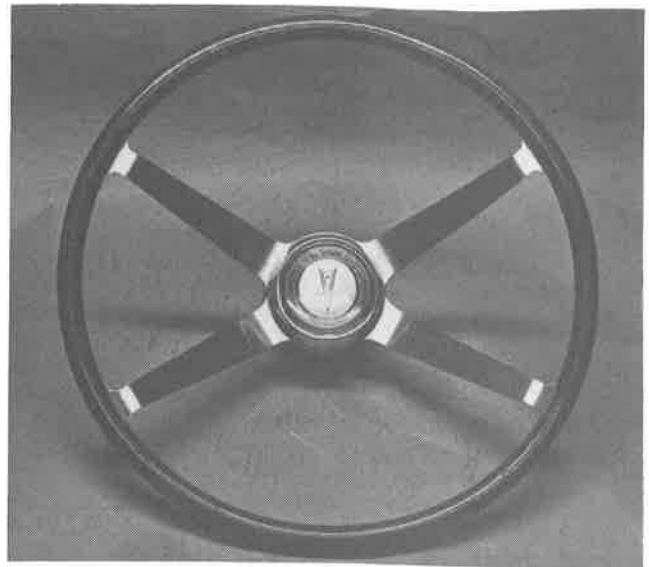

Detail of 1964 Custom Sport wood wheel (RPO 524). Spokes were made of stainless steel. Available in 1964 only.

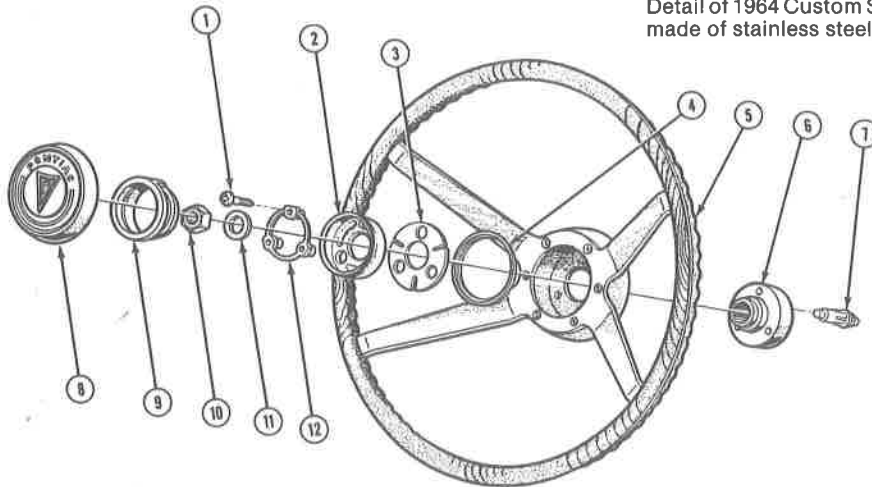

Key	Part Name	Group No.	Key	Part Name	Group No.
1	SCREW, Horn Ring Spacer Bushing (#10-32 x 3/4")	2.821	7	CONTACT & SPRING ASM., Horn Button	2.819
2	CUP, Horn Button Contact	2.821	8	CAP, Steering Wheel-Includes Ornament	2.817
3	SPRING, Horn Button	2.819	9	RETAINER, Horn Button Cap	2.821
4	INSULATOR, Horn Contact Spring	2.819	10	NUT, Wheel Asm. to Steering Shaft (1/2"-20)	6.515
5	WHEEL, Steering (Wood)	6.513	11	WASHER, Wheel Asm. to Steering Shaft (17/32" I.D. x 15/16" O.D.)	6.515
6	HUB, Steering Wheel	N.S.	12	BUSHING, Horn Button Cup Spacer	2.821

Exploded view of 1964 Custom Sport steering wheel and parts nomenclature.

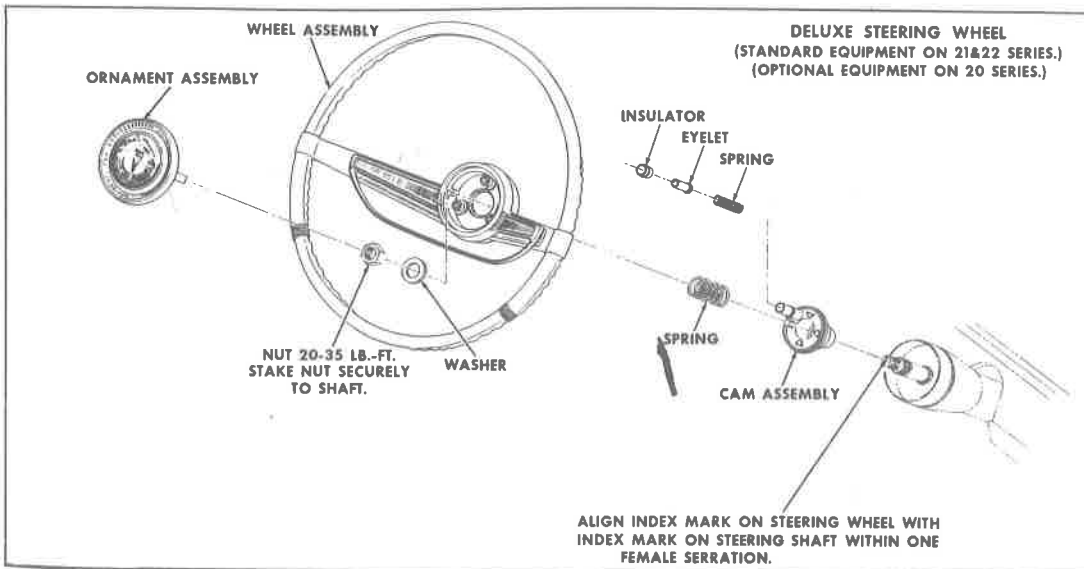

Installation of 1964 GTO Deluxe steering wheel. The horn ring used part number 9740478, and the ornament was serviced by part number 9774189.